

**Request for Information**  
**N00014-16-R-RFI4**  
**Electromagnetic Maneuver Warfare Command & Control (EMC<sup>2</sup>)**  
**Low-band Radio Frequency Intelligent Distribution Resource (LowRIDR)**

**I. DISCLAIMER**

This announcement constitutes a Request for Information (RFI) for the purpose of conducting market research for the Electromagnetic Maneuver Warfare Command and Control (EMC<sup>2</sup>) Low-band RF Intelligent Distribution Resource (LowRIDR) concept. The Office of Naval Research (ONR) is soliciting feedback on the LowRIDR concept; draft requirements; related technology; recommendations/considerations for LowRIDR Advanced Development Model (ADM) subsystems; and information on the availability of critical technologies and/or components that might support a LowRIDR solution. The LowRIDR concept was developed under the Integrated Topside (InTop) Innovative Naval Prototype (INP); the development, integration, test and demonstration of the ADM subsystems will be accomplished under the Electromagnetic Maneuver Warfare Command and Control (EMC<sup>2</sup>) INP.

This information may be used by the Government to refine requirements for the development and acquisition of one or more LowRIDR ADM Band<sup>1</sup> subsystems/units.

This RFI does not constitute a Request for Proposal (RFP), a Request for Quote (RFQ) or an indication that the Government will contract for any of the requirements discussed in this notice. Information on the specific topics of interest is provided in the following sections of this announcement. Neither ONR nor any other part of the federal government will be responsible for any cost incurred by responders in furnishing this information.

**II. BACKGROUND**

**A. Program**

ONR established the InTop INP to develop and demonstrate common Radio Frequency (RF) apertures and supporting subsystems capable of performing multiple functions to support multiple warfare areas. The Navy wants to increase Fleet warfighting capability while reducing the number of single function RF systems required on Navy ships and submarines.

ONR's EMC<sup>2</sup> INP is building upon the work that was done under InTop to develop additional multi-function capabilities as well as the Command and Control (C2) to enable those capabilities to work together as a system of systems. As such, EMC<sup>2</sup> will develop hardware and software intensive systems that provide the capability to monitor the RF spectrum across a wide range of frequencies and reallocate functions to the best frequencies and resources to respond to changes in the electromagnetic environment and warfighter requirements.

---

<sup>1</sup> The LowRIDR System will consist of 5 frequency bands. This RFI and initial acquisition will focus on Bands 3 and 4.

The objectives of the EMC<sup>2</sup> LowRIDR System<sup>2</sup> are to reduce the number of dedicated antennas utilized for Communications (Comms) and Information Operations (IO) in the HF thru C-band regions of the spectrum; to expand and incorporate traditional Electronic Warfare (EW) functionality into these lower bands; to incorporate Open Architecture (OA) principles and a Modular Open System Approach (MOSA); and to permit flexibility in the allocation, management, and optimum use of the various LowRIDR assets and associated spectrum. LowRIDR is focused on specific RF capabilities: Communications (Comms) (including Link-16, Identification Friend or Foe (IFF), and Tactical Air Navigation (TACAN)), Information Operations (IO), Electronic Warfare (EW), and Real-Time Spectrum Operations (RTSO).

## B. System

The notional LowRIDR system is described in the draft System Documents and the block diagrams shown below (figures 1 and 2). They are intended, together with Paragraph C, entitled, “Goals of the LowRIDR Program” to outline the Navy’s LowRIDR goals and requirements, and are presented at the highest level possible to allow the greatest flexibility in system design for achieving an affordable LowRIDR system which will satisfy the above objectives.

These draft System Documents were prepared by a joint Navy-Northrop Grumman Corporation (NGC) System Engineering team:

- LowRIDR Draft ADM System Specification (SS) (Unclassified with Classified appendix)
- LowRIDR Draft ADM Architecture Description Document (ADD)
- LowRIDR User System Descriptions.

Figures 1 and 2 show the latest draft system architectures for the objective LowRIDR Engineering Development Model (EDM) that would cover HF through C-band, and the LowRIDR ADM that is focused on Bands 3 and 4.

Selected band breaks:

- Band 1: Rx 0.1 – 30 MHz & Tx 2 – 30 MHz
- Band 2: 25 – 115 MHz
- Band 3: 100 – 525 MHz
- Band 4: 0.5 – 2.7 GHz
- Band 5: 2 – 8 GHz

---

<sup>2</sup> The term “InTop” refers to the overarching InTop System of Systems; references to “InTop Systems” refer to individual systems that are considered to be one (or more) of the overarching InTop System of Systems.

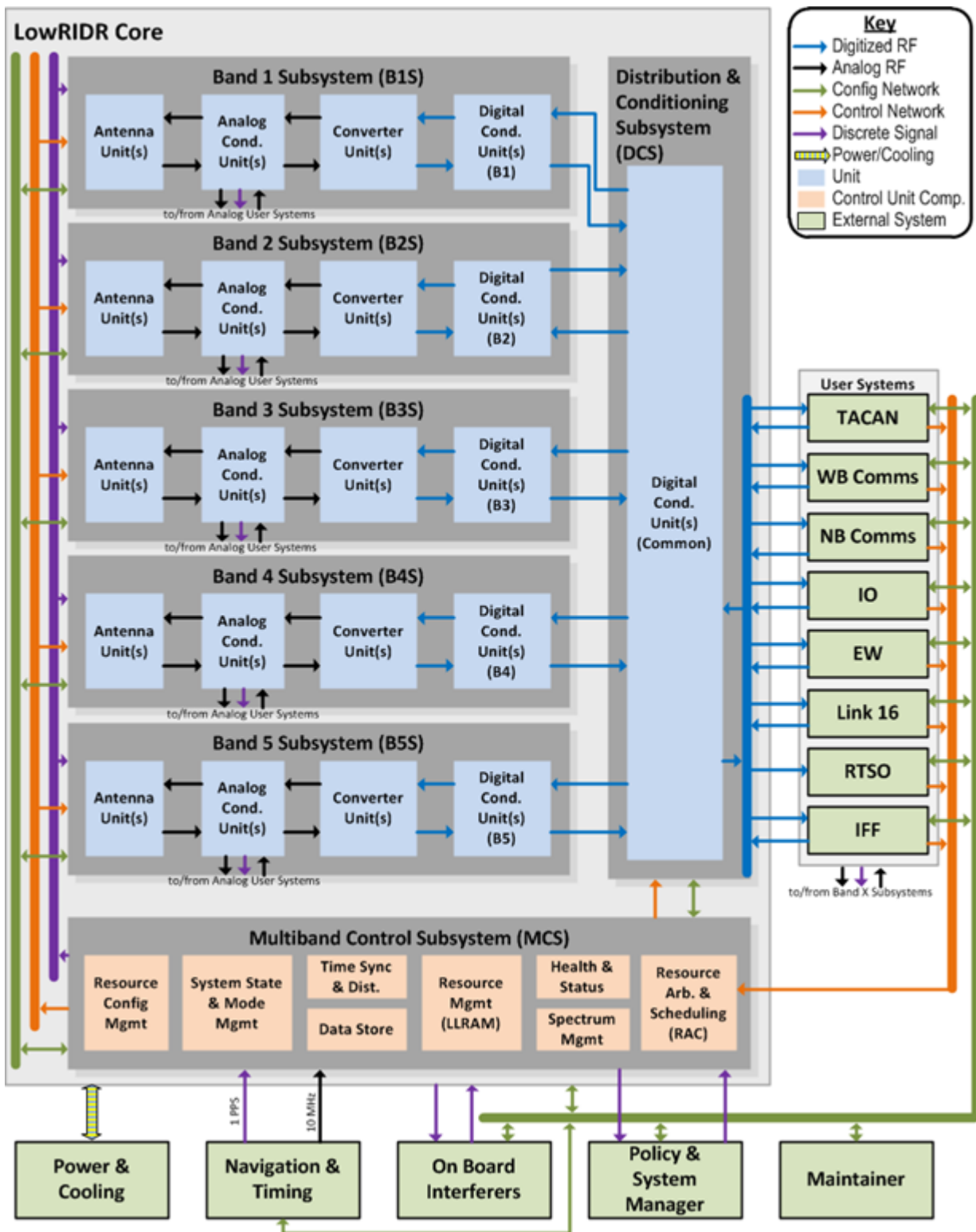

Figure 1 System Architecture Future EDM Vision

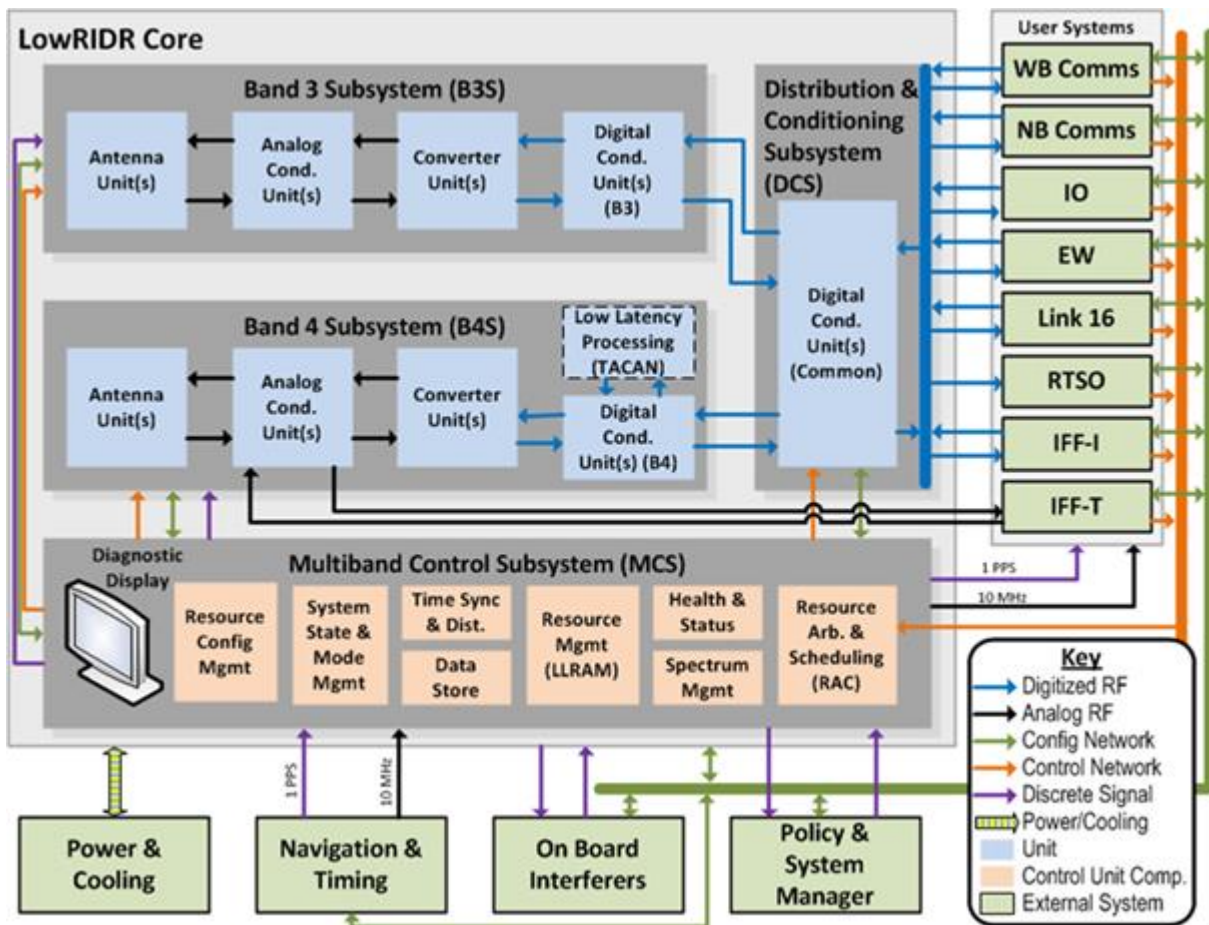

Figure 2 ADM System Architecture

LowRIDR will initially concentrate on Line of Sight Communications (TACAN, IFF, and Link-16) and enhancement of the SIGINT and IO functions across the selected bands. Within the LowRIDR system architecture, EW will also capitalize on LowRIDR’s ability to conduct Electronic Support (ES) and Electronic Attack (EA) within the extended frequency range.

### C. Goals of the LowRIDR program

The goals of the LowRIDR program include the following items. These represent a preliminary set of program goals which may be further refined during the RFI process.

- 1) Reduce the number of dedicated antennas utilized for Comms, IFF, TACAN, IO, EW, and other RF functions in the HF through C-band regions of the spectrum by consolidating these functions into a common set of shared antennas and processing equipment wherever possible/practical.
  - a) LowRIDR antennas should operate over wide segments of the HF to C-band region and are divided into specific frequency bands to optimize antenna characteristics and User System frequency spectrum requirements. A User System is a system which implements specific operational requirements by using LowRIDR multifunction assets to transmit and/or receive RF signals.

- b) The LowRIDR ADM will address two of five designated frequency bands (see Section II. entitled, “Background” paragraph B entitled, “System”).
- 2) Enable the common set of LowRIDR antennas to provide directional beams as well as traditional, omnidirectional capabilities. Benefits for Comms, IFF, TACAN, IO, and EW functions, include:
  - a) Enable point-to-point communication signals that currently use omnidirectional antennas to operate with less radiated power, lower probability of intercept, more immunity to electromagnetic interference (EMI), and greater operational performance.
    - i) Some communication links may require a new concept of operations to implement directional connectivity.
  - b) Enable RF functions to share common front-end hardware and coordinate EMI mitigation.
  - c) Provide omnidirectional capability for both transmit and receive functions when operationally required.
  - d) Provide User Systems with necessary antenna resources for direction finding.
- 3) Provide a common/open signal distribution system between LowRIDR and the respective User Systems’ receivers and exciters.
  - a) This signal distribution system shall be implemented using an open, digital interface standard to simplify equipment interconnection.
  - b) The signal distribution system should provide access to any portion of the LowRIDR spectrum for transmit (Tx) and receive (Rx) by any of the functions.
  - c) LowRIDR shall be compatible and operate with both legacy and new Comms, IFF, TACAN, IO, and EW systems; adapters may be required to interface with some legacy systems; surrogates may be required to replicate new functional capabilities.
- 4) Provide better coordination between RF functions within the band of coverage; exercise Spectrum Management.
  - a) Enable the Comms, IFF, TACAN, IO, and EW functions to coordinate their spectral (and spatial) usage
    - i) Interface with and support the Spectrum Control functions of the RTSO
  - b) Enable improved Electromagnetic Compatibility (EMC) with other active and passive sources and sensors; both onboard and off board own ship.
- 5) LowRIDR shall be developed with a Modular Open Systems Approach (MOSA).
  - a) The system shall support the use of common equipment for RF front end conditioning of Comms, IFF, TACAN, IO, and EW waveforms wherever possible.
  - b) The System design shall identify a set of key functional building blocks/modules and corresponding interfaces that the Navy will own and maintain to permit technology refresh, and other system modifications (new terminal integration, etc.).
  - c) LowRIDR shall be capable of being scaled to support the operational and design requirements of both new and legacy classes of ships.
- 6) Equipment shall be controlled by an overall system controller, which utilizes the InTop Low Level Resource Allocation Manager (LLRAM) and associated infrastructure.
  - a) Provided as Government Furnished Software (GFS) for this effort.

- 7) LowRIDR Equipment shall interface with surrogate/representative User Systems.
  - a) Provided as Government Furnished Equipment (GFE).
  - b) The tasking for the LowRIDR System can come from real and/or surrogate Comms, IFF, TACAN, IO, EW, Combat System.
  - c) An engineering-grade Human Machine Interface (HMI) shall be included with the Multiband Control Subsystem (MCS) for manual control during integration, test and maintenance.
  
- 8) Multi-Level Security Interfaces
  - a) The LowRIDR Program will address the multiple enclaves represented by the multiple Comms, IFF, TACAN, IO, EW and RTSO constituencies in the design. The architecture shall identify where multi-level (e.g., classified/unclassified) interfaces are required.
  - b) The LowRIDR architecture should minimize multi-level security interfaces that require special NSA approved equipment (cross-domain solutions).

### **III. RFI OBJECTIVE**

ONR is seeking comments on the InTop/EMC<sup>2</sup> Program Office's concept for the development and demonstration of one or more LowRIDR ADM subsystems/units.

Interested Suppliers are requested to comment on the feasibility of the above LowRIDR goals/concept, and related requirements and specifications as they relate to LowRIDR as a whole and/or the planned ADM development of the Band 4 and Distribution & Conditioning Subsystem (DCS), and subsequent Band 3 and DCS subsystems. Comments should include suggested refinements to these concepts and requirements based on familiarity and knowledge of technology and/or components that might improve or better enable LowRIDR capabilities in operational performance, topside integration, system support and/or affordability.

### **IV. SPECIFIC INFORMATION OF INTEREST**

Comments to this RFI should include some or all of the following information relevant to the LowRIDR ADM development:

- 1) Comments on the feasibility of the LowRIDR concept, and related requirements, specifications and ADD as they relate to LowRIDR as a whole and/or the planned ADM development of the Band 4 and DCS subsystems and subsequent Band 3 and DCS subsystems. Also describe the commonality that might be expected between the DCS needed for Band 4 demonstration and the DCS functions required for Band 3 so that the DCS might be in a single subsystem/unit (or share common interfaces and maintain MOSA). Comments should include suggested refinements to these concepts and requirements based on familiarity and knowledge of technology and/or components that might improve or better enable LowRIDR capabilities in operational performance, topside integration, system support and/or affordability. Comments on the GFI system requirements, specifications and ADD shall be provided in the attached "LowRIDR-RFI-Comments Template" identifying the specific location of recommended corrections or modifications.

- 2) Outline of an approach to architect and develop one or more LowRIDR subsystems and/or critical components
- 3) Identify critical interfaces between subsystems/units/components, and within the individual Band 4 and/or Band 3 subsystems
- 4) Identify critical hardware/components and software/algorithms, and describe approach and/or offering available to address these needs.
- 5) Provide a subsystem level notional design of at least one subsystem (Band 4 & DCS and/or Band 3 & DCS)) that is designed to satisfy all of the requirements provided in the attached documents. Multiple approaches may be presented. Subsystem designs should include, but not be limited to, the following information:
  - a) Description of the overall subsystem architecture
  - b) Listing of key enabling technologies assumed
  - c) Estimates of key performance parameters for the proposed system
  - d) Description of any departures from the requirements and the reason for the departure
  - e) Rough Order of Magnitude (ROM) Cost estimate for proposed LowRIDR ADM subsystem(s) to be developed
- 6) Although this RFI is primarily interested in current capabilities to produce an ADM for test and demonstration of the LowRIDR concept, there is also considerable interest in the path from the demonstrated capabilities to a fielded, tactical system. To that end, comments should also include:
  - a) Identification of critical technology that should be addressed as part of the ADM development in order to satisfy the system requirements, or in parallel to more rapidly transition to EDM. Comments should include an assessment of maturity (i.e., Technology Readiness Level (TRL)<sup>3</sup>) and recommended steps to progress to TRL 6.
  - b) An assessment of the design changes that might be needed to transition to a fully tactical shipboard system and the ways they could be implemented within the proposed notional system architecture, and
  - c) Other impacts such a system approach may have on overall life cycle costs (LCC) for the ship.

## **V. SUBMISSION INSTRUCTIONS AND FORMATTING REQUIREMENTS**

- 1) Comments should be no more than twenty five (25) pages, not including cover page and Rough Order of Magnitude (ROM) cost estimate, and should be typed in 12-point Times New Roman font, single spaced, with 1-inch margins. Comments focusing on a subset of the requested information should be correspondingly reduced in length.
- 2) The following is a suggested comment submission organization:

---

<sup>3</sup> The Technology Readiness Assessment (TRA) Guidance document, dated April 2011 found at the following website (<http://www.acq.osd.mil/ddre/publications/docs/TRA2011.pdf>), includes TRL definitions. Use those definitions for identifying the TRL.

- a) Notional system design and analysis of capabilities as described in section IV entitled, “Specific Information of Interest”.
  - b) The comments shall include the RFI number and name, address, company, and technical point of contact with printed name, title, email address and date.
  - c) ROM cost estimate not more than 1 page. (Not included in the page count)
  - d) Attachments with comments, questions and suggested changes to the draft System Documents made in the “LowRIDR-RFI-Comments Template” identifying, where applicable, the specific location of recommended corrections or modifications.
- 3) The Government intends to review all comments received and reserves the right to use the comments to refine the LowRIDR requirement and develop a solicitation.
  - 4) After review of the comments the Government may request additional information.
  - 5) Comments will not be shared outside the Government and Government support contractors. Comments will not be shared with the Government’s LowRIDR system engineering contractor: Northrop Grumman Corporation.
  - 6) If proprietary information is submitted, it must be portion marked at the paragraph level to indicate those specific paragraphs that contain proprietary information.
  - 7) All comments received in response to this RFI that is proprietary will be protected against unauthorized disclosure in accordance with FAR Subpart 15.207, applicable law, and DoD/DoN regulations.
  - 8) Unclassified comments are desired. If a classified supplement is necessary to more fully reply to the subject RFI questions it should be submitted separately along with the annotated “LowRIDR-RFI-Comments Template” addressing the classified SS appendix. See paragraph number 11 below for mailing instructions for classified supplements.
  - 9) Comments are due no later than Thursday 18 February 2016 at 2PM Eastern Local Time. Any comment received after this date may be considered but may not be included in subsequent refinement of the LowRIDR requirement and development of a solicitation.
  - 10) All unclassified comments shall be in PDF format and emailed to the following:

Betsy DeLong at [betsy.delong@navy.mil](mailto:betsy.delong@navy.mil)  
Diana Arceo at [diana.arceo@navy.mil](mailto:diana.arceo@navy.mil)  
Lynn Christian at [lynn.christian@navy.mil](mailto:lynn.christian@navy.mil)  
Greg Tavik at [greg.tavik@nrl.navy.mil](mailto:greg.tavik@nrl.navy.mil)  
Norman Thomas at [norman.thomas.ctr@nrl.navy.mil](mailto:norman.thomas.ctr@nrl.navy.mil)



11) Classified Supplement Mailing Instructions:

Classified supplements shall be submitted directly to the attention of ONR's Document Control Unit at the following address:

OUTSIDE ENVELOPE (no classification marking):

Office of Naval Research  
Document Control Unit  
ONR Code 43  
875 North Randolph Street  
Arlington, VA 22203-1995

The inner wrapper of the classified supplement should be addressed to the attention of Ms. Betsy DeLong (betsy.delong@navy.mil) Code 312 and marked in the following manner:

INNER ENVELOPE (stamped with the overall classification of the material):

“LowRIDRComments”  
Office of Naval Research  
Attn: Ms Betsy DeLong  
ONR Code: 312  
875 North Randolph Street  
Arlington, VA 22203-1995

12) Comments will not be returned.

13) Some topics in this RFI cover export controlled technologies. Research in these areas is limited to "U.S. persons" as defined in the International Traffic in Arms Regulations (ITAR) - 22 CFR § 1201.1 et seq. RFI responses and any other communication on this topic shall be limited to only such ITAR qualified "U.S. persons"/companies.

14) Copies of the following documents will be mailed on CD ROM to DoD contractors only (in accordance with Standard Distribution D and above ITAR restrictions) on request to Lynn Christian at [Lynn.Christian@navy.mil](mailto:Lynn.Christian@navy.mil) Please include company name, company cage code, company classified mailing address, a current DoD contract number along with the government Point of Contact (POC) for that contract and the contact information for your Joint Certification Program POC. The ONR will use this information to verify eligibility to receive Distribution D, export controlled and classified information. Requests for exceptions to the Distribution D DoD contractor requirement may also be submitted to Ms Christian.

- LowRIDR Draft ADM System Specification (SS) (Unclassified with Classified appendix)
- LowRIDR Draft ADM Architecture Description Document,
- LowRIDR User System Descriptions
- LowRIDR-RFI-Comments Template

## **VI. FUTURE PROCUREMENT**

The ADM procurement process may be made through, although not limited to, the EMC<sup>2</sup> Indefinite Delivery Indefinite Quantity contracts or the U.S. Army Contracting Command-New Jersey Other Transaction Agreement procured through the National Spectrum Consortium (NSC).

## **VII. ACQUISITION BACKGROUND**

The background information for this acquisition is as follows:

- 1) The Government expects to revise and refine the LowRIDR requirements and specifications based on the comments received from this RFI. Specific proprietary information will be protected but may be used without attribution in considering the feasibility (technical and cost) of a particular requirement and architecture, and the maturity of a critical technology.
- 2) Northrop Grumman Corporation (NGC) is contracted for and teamed with the Navy for the System Engineering, Integration and Test (SEIT) of the LowRIDR ADM System. As such NGC participated in the draft preparation of the attached LowRIDR system documents, and will continue to participate with the Navy in finalizing these documents in preparation for ADM acquisition. On award of subsequent LowRIDR ADM subsystem/component task orders NGC will continue their support of the Navy in the System Engineering oversight, integration and test of these efforts. In addition NGC will develop the LowRIDR Multiband Control Subsystem (MCS) which will integrate with and provide system control and configuration to the band specific subsystems. Northrop Grumman's SEIT Task Order includes a Hardware exclusion requirement excluding NGC from participating in any other LowRIDR System ADM efforts. This Task Order also includes a requirement for NGC to enter into an Interface Working Agreement (IWA) with any other organization developing another portion of the LowRIDR ADM or with vendors responsible for specific external interfaces or equipment with which the system must integrate. The purpose of the IWA is to ensure liaison and interchange of technical interface and programmatic information with other vendors as the system is developed, and will be similarly required of all participating suppliers. NGC will not participate in competitive supplier selection and will be excluded from any specific proprietary technical and/or program interchanges, including any proprietary information provided with your response to this RFI.
- 3) In an effort to facilitate subcontracting opportunities, if a responding contractor would like the government to share nonproprietary, unclassified ideas related to the LowRIDR effort with other members of Industry, please include no more than five (5) slides in Microsoft PowerPoint or Adobe PDF as a supplement to your white paper response and indicate that this PowerPoint material may be provided to other interested LowRIDR parties (subject to the distribution requirements stipulated

above).

The Government currently intends to procure the LowRIDR ADM in a phased approach. The first phase will develop the Band 4 Subsystem and associated DCS. The second phase will develop the Band 3 Subsystem and associated DCS. The Band 3 DCS development, however, shall allow for integration into the previously developed Band 4 DCS architecture to enable User Systems access to resources in either frequency band.

## **VIII. QUESTIONS:**

Questions shall be sent to:

Dr. Diana Arceo  
SPAWAR Systems Center Pacific, Code 52270  
53560 Hull Street  
San Diego, CA 92152-5001  
Email: diana.arceo@navy.mil

and

Lynn Christian  
ONR Code BD 0251  
Office of Naval Research  
875 North Randolph Street, Suite W1275  
Arlington, VA 22203-1995  
Email: lynn.christian@navy.mil

Any questions shall be submitted in writing by electronic mail.

Questions submitted within 2 weeks prior to the closing date of this RFI may not be answered.

Amendments with responses to questions received under this RFI will be posted to the following webpages:

- Federal Business Opportunities (FEDBIZOPPS) Webpage - <https://www.fbo.gov/>
- ONR Broad Agency Announcement (BAA) Webpage <http://www.onr.navy.mil/en/Contracts-Grants/Funding-Opportunities/Broad-Agency-Announcements.aspx>